

**SIMPLEX INDUSTRIES, INC.**  
**2022 GENERAL INFORMATION & POLICIES**

**A. GENERAL COMMENTS:**

1. SIMPLEX INDUSTRIES, INC. - Reserves the right to change or discontinue models, specifications, plans, materials, designs, or prices at any time without notice and without incurring obligations. It is understood and agreed that Independent Builder/Purchaser, (herein referred to as Purchaser) is not an agent or employee of Simplex in any manner and that the Purchaser is an independent contractor with special knowledge of the nature of the work and the responsibility involved herein and that the Purchaser's status as such shall be so construed in any actions involving Simplex, the Purchaser or Third Party. This relationship is not an exclusive arrangement for either party. Independent Purchaser is not obligated to place any order with Manufacturer and Manufacturer has the right to refuse, for any reason, an order received from Independent Purchaser. It is further distinctly and expressly understood and agreed that the Purchaser is in no way authorized to incur any obligation or indebtedness that will, in any way, bind Simplex or make Simplex liable, therefore nor shall Simplex become liable for any such engagement, contract or purchase made by the Purchaser. In addition, all houses are sold to the Purchaser thus; any complaints or service requests are to be submitted by the Purchaser, not their Third-Party customer.
2. Simplex Industries, Inc. prohibits alterations to this document and accepts no liability or responsibility for alterations made to this document by others.

**B. ORDERING REQUIREMENTS AND PROCEDURES:**

Home orders submitted for acceptance by Simplex Industries, Inc. must include the following:

1. All specifications of the house including model, size, type, colors and materials and all desired options.
2. A confirmation copy of the Sales Contract signed by the Purchaser indicating that the listed specifications are correct.
3. A copy of the print signed by the Purchaser indicating that the house, as drawn on the print, correctly lists any requested floor plan changes to Simplex Industries, Inc. standard floor plan.
4. a. Deposit amount for single family home orders is as follows:
  - Subtotal costs up to \$100,000 = 15% deposit
  - Subtotal costs from \$100,001 to \$150,000 = 20% deposit
  - Subtotal costs from \$150,001 and \$499,999.99 = 25% deposit
  - Subtotal costs \$500,000 and above the following payment schedule will apply.
    - 25% deposit at time of order
    - 45% upon units going into production
    - 25% upon the units coming off the production line
    - 5% upon the units being delivered to the site
- b. (25%) of the subtotal on all multi-family and light commercial products under a \$500,000 subtotal.
  - Subtotal costs for multi-family \$500,000 and above the following payment schedule will apply.
    - 25% deposit at time of order
    - 45% upon units going into production
    - 25% upon the units coming off the production line
    - 5% upon the units being delivered to the site
- c. Special Order Materials Deposit – due to highly specialized building materials or extended procurement times, Manufacturer reserves the right to request a Special-Order Materials Deposit which is in addition to the above listed deposit schedule.
- d. All Production and Special-Order Materials Deposits are Non-Refundable: any exceptions are only at the discretion of the President and will be considered on a case-by-case basis.

5. A completed Purchaser/Credit Application Form.
6. A completed Purchaser Acknowledgement Form.
7. Prior to production of a home, a shop drawing release form and print will be sent to Purchaser for verification that the home as drawn matches original order and print submitted. This is not intended for the customer to make changes that alter original home order and/or print.
8. Signed Notice to Proceed into manufacturing.

**C. CHANGE ORDER POLICY:**

1. Acceptance of any change order is at the discretion of Simplex Industries, Inc.
2. A minimum of \$50.00 processing fee will be charged for any change order after 5 calendar days of receipt of order.
3. A minimum of \$200.00 processing fee will be charged for any change order accepted within 12 calendar days of scheduled online date of the order.
4. Any changes that alter an already drawn shop plan will incur an additional charge of \$200.00 to the above processing fee.
5. Simplex reserves the right to reject any change orders after 5 calendar days of the receipt of the order.
6. No change orders will be accepted within 3 calendar days of the online production date.

**D. ACCEPTABLE METHODS OF PAYMENT:**

1. Payment for the home will be the balance including freight and tax in the form of a Bank Certified Check or Bank Cashier's Check at time of delivery. Company checks are not an acceptable method of payment. The following list is a description of the approved methods of check payments to Simplex Industries, Inc. Note: Payment for independent escort cars is not included above and must be paid directly to each independent escort driver on the day of delivery.
  - a. A Bank Certified Check or Bank Cashier's Check made payable to Simplex Industries, Inc. (only). Note: there is to be No Notation on the check with the retail customer's name, such as "Mortgage Proceeds - Retail Customers Name", or, "Construction Advance - Retail Customers Name."
  - b. A Bank Cashier's Check payable to a Simplex Purchaser, and endorsed on the back by the Purchaser, "Payable to Simplex Industries, Inc."
  - c. A Retail Customers Certified Check payable to a Simplex Purchaser, and endorsed on the back by the Purchaser, "Payable to Simplex Industries, Inc."
  - d. Wire transfer or ACH transfer received prior to trucks unhooking the unit(s) at time of delivery.
2. Assignment of Funds: From time to time, it may be necessary to use an alternate acceptable form of payment in an Assignment of Funds document. When using our standard document Simplex will charge a \$500.00 processing fee and a \$250.00 interest fee per day for each day payment is not received from date of delivery, not including the date of delivery. The processing fee amount will be added on the order at the time of the order being processed. When the home must be set before payment will be made, we will require an additional \$1,000.00 carrier deposit on the house order form to cover possible expense due to delayed payment. The \$250.00 charge will be deducted for the carrier deposit if it is not paid at the time when the house balance is paid (no exceptions.) If modifications are considered, an additional fee of \$250.00 must be added to the above \$500.00 fee for the preparation of the document.
3. The home must be delivered and paid within (28) Twenty-Eight calendar days after Scheduled Off Line Date. Any home not paid in full prior to the Twenty Eighth calendar day after the Scheduled Delivery Off Line Date will be subject to storage fee of \$750.00 per month/per carrier that will automatically be added to the final invoice and continue to accrue monthly until payment is received. The storage fee is retroactive back to the first calendar day after the first module offline.

4. If full payment is made for the unit, but the purchaser is unable to take delivery of unit and it must remain in the finished goods storage yard the following terms and conditions will apply:
  - The purchaser of the unit is responsible to verify within 3 business days after the payment has been made, any defects that exist at this time. Failure by purchaser to inspect the units within 3 business days waives purchasers right to the inspection and unit is deemed to be in good condition and free of any visual defects in workmanship. Any defects that occur after the inspection period (notably but not limited to defects that occur due to the weather) are the sole responsibility of the purchaser.
  - Purchaser is responsible to advise Simplex in writing of the type of weather protection they would like, if any. Protective tarps can be purchased or an additional layer of plastic can be applied over the original protective plastic. These methods are not guaranteed to prevent weather damage but are recommended to protect your investment.
  - It is fully understood that the purchaser is responsible to advise Simplex to add additional weather protection and it is also understood that payment must be made in advance of any of these provisions being done. Costs for these provisions will be provided to the purchaser at time of request.
  - Simplex reserves the right to charge a \$25.00 per day per carrier rental fee for units that remain in storage yard for 30 days after payment is made in full for units.
5. All wire and/or assignment of funds payments, regardless of payor, received by Manufacturer, for a specific Order, will be deemed, by Manufacturer, as paid on behalf of the Purchaser for that Order. If the payment is more than the agreed upon final invoice amount, Manufacturer shall, upon verification of funds, refund the over-payment to the Purchaser.

**E. CREDIT CARDS:**

1. Simplex Industries will accept payment via credit cards. These payments will only be permitted for engineering and print requests, and for requests for shipment (RFS for building materials). We can accept credit card payments from VISA, MasterCard, Discover, American Express, Diners Club International, and Union Pay. Please note, we will only accept credit card payments from our PURCHASER. We cannot accept credit card payments (or any other payments) from Purchaser's customers. NO EXCEPTIONS. Payments can be processed over the phone, or in person in the accounting department. The Assistant Controller is responsible for processing and posting all credit card from offsite, they will need to call in and speak with the Assistant Controller to process the payment.

**F. DELIVERY CONFIRMATION:**

1. The Purchaser must be in contact with the Simplex Transportation Department as soon as possible to reserve and confirm a delivery space in the Simplex trucking schedule. Please make sure that you are going to be ready to accept delivery on the confirmed delivery date. Before you can reserve the space in the delivery schedule you must sign the Delivery Confirmation Form a minimum of ten (10) calendar days prior to delivery to reserve the trucks for the exact date you want them. You must provide complete, accurate directions and a site map before the Delivery Confirmation Form will be accepted. There will be a \$250.00 per carrier fee for any cancellations made within 10 calendar days of the shipping date, plus the Purchaser will incur any permit costs that are accrued. Please consult with your Simplex Account Manager to review the Delivery Confirmation Form prior to placing your home in the production schedule.
2. It is Simplex's policy that the Purchaser should not set the home the day the home is delivered. The Purchaser is assuming all risks involved in same day sets, they must be aware that Simplex reserves the right to use one truck on two or more boxes depending on the distance. In addition, we cannot be responsible for any delays caused by our arrival being delayed. Unforeseen circumstances may have our drivers arriving later than you had anticipated, which, in turn, may add costs to your set up and/or crane crew. Simplex will make its best effort to deliver your home as early as possible, but we cannot guarantee the arrival time of the driver.

3. Delivery charges are calculated on the information provided by the Purchaser at the time of order. Simplex reserves the right to adjust the charges, if costs are incurred due to inaccurate or lacking information. Detours are the responsibility of the Purchaser and will be invoiced later. Due to fluctuations in fuel, and/or other costs, Manufacturer may, at any time, (including after signing this contract or after production has begun) adjust prices for delivery quoted to Purchaser.

**G. SITE PREPARATION BEFORE DELIVERY:**

1. Provide accessibility to house site. Driveway entrance must be wide enough to allow turnoff from road. Driveway should be smooth, level and clear of branches, wires, etc. to avoid damage to the Units. Any additional costs to achieve delivery to your home-site are the responsibility of the Purchaser (beyond standard mileage rates and State permits.)
2. Crane Accessibility and Pad Preparation.
  - a. Consult with your set crew and crane company concerning the specific details of your jobsite.
  - b. Access to the jobsite should be prepared so the crane can be positioned in a location that allows it to safely set each module.
  - c. Prepare a level crane pad area with a solid base, free of overhead obstructions (trees, wires, etc.). Adequate bracing of the foundation all may be required.
  - d. A crane pad must be:
    1. On virgin soil or compacted sufficiently to support the crane
    2. Within 6 inches of level from corner to corner
  - e. Provide a level area for the carrier to be parked near the crane. Adequate space for maneuvering is required around the foundation.
  - e. If a prefabricated foundation system is being utilized, such as a "Superior Wall", consult your foundation supplier for details for site preparation.
3. All foundation plans and notes provided by Simplex are for reference only. It is solely the Purchasers responsibility to hire a licensed Professional Engineer to design, supervise the construction of, and inspect all aspects of the foundation prior to the setting of the modular unit (s). The Purchaser must comply with all state and local code requirements.
4. The intent of the suggested foundation plan in the permit set is provided to illustrate gravity and uplift load information, column and/or pier locations, and any hold-down requirements. It is not intended to be used as a final design document for the foundation. The Purchaser is responsible to have the foundation designed and engineered by a Design Professional based on the information provided on the suggested foundation plan, site and soil conditions, and local code requirements.
5. The Purchaser is to have all materials on site for set up of the home. This includes the proper support columns, jack posts or piers. The foundation needs to be checked for squareness and levelness within the recommended tolerances. All foundation dimensions should be verified that they match the final floor plan dimensions. Make sure sill plates, sill sealer and any required hold-downs are installed on the foundation prior to home installation
6. Strapping and hold downs may not be included. In this case, it would be the Purchaser's responsibility to provide any necessary hold-downs based on the information from the final engineered foundation plan provided by the Purchaser Design Professional

**H. UPON ARRIVAL OF UNITS AT VICINITY OF BUILDING SITE:**

1. You or your company representative must meet our driver at a pre-determined location to direct him to the building site for the Purchaser's acceptance and payment of home. Independent escort car charges are to be paid to each independent escort car driver. (Note: Any layover expenses incurred by escort cars must be paid at this time.) Independent escort car/drivers are not employees of Simplex Industries.

2. You or your company representative must inspect and sign for the home. Any shortages or obvious damage must be noted on The Home Inspection Report at this time in order to qualify for service or parts replacement at no charge. See Service/Parts Policy.
3. SIMPLEX INDUSTRIES, INC. intended delivery is to the curb. When the Unit or Units leave the main road, or the delivery is impeded by unsafe or un-passable conditions, any further transportation costs (such as tow charges, etc.) are the responsibility of the Purchaser. Please note: Simplex will not take responsibility for delivery on a non-paved road area or unsafe delivery conditions. Be prepared with proper on-site equipment, which may be necessary to pull the Units onto the construction site.  
NOTE: Simplex reserves the right to stop delivery and receive a liability waiver and/or house payment from the Purchaser if Driver determines home site access to be impassable, impaired, improper, unstable, or unsafe. It is the responsibility of the Purchaser to provide a safe access way to the job site. When the access way is determined to be unsafe, Purchaser agrees to make immediate payment. Simplex reserves the right to demand immediate payment before considering to continue the delivery. If access as planned by the Purchaser is too dangerous to proceed, The Purchaser will arrange for disposition or storage of the Units and shall pay the driver the full invoice amount as if the Units had been delivered to the job site. Any additional costs incurred or caused by delays shall be paid by the Purchaser.
4. Purchaser is responsible, at its expense, to have equipment capable of moving the Units once on the job site. Said equipment shall be located at the delivery site at time of delivery.
5. When the SIMPLEX driver arrives at the pre-determined destination, a one-hour waiting/check-in period will be maintained at no charge to the Purchaser. Any waiting time over one hour will be billed at the rate of one hundred dollars (\$100.00) per hour, per driver, which will be deducted from the carrier deposit.

**I. INSTALLATION OF THE HOME:**

It is the Purchaser’s responsibility to make arrangements for the set crew and crane to be at the job site. Simplex Industries, Inc. has the name of set crews in most building areas. It is the Purchaser’s responsibility to keep the set crew informed as to the status of the set. The cost of the set should be negotiated with the set crew in advance of the set to avoid any misunderstanding on the day of set. Consult your set manual and drawings that were given to you for specific information on the setting of your modular building. The field set crew will typically perform the following:

**Field Installation Work Check List**

1. Remove close-in materials and flush all staples and nails from all mate walls.
2. Inspect and verify that all parts necessary for the completion of the set are present and correct.
3. Simplex Industries, Inc. requires certain pick points based on module length and configuration. Refer to the “Site Installation Manual” for these details.
4. It is the Purchaser responsibility to direct the set crew to properly seal the exterior of the home during the set, in order to comply with the 2012, 2015 and 2018 IECC, Energy Star, Stretch Code or other codes for the particular area they are building in), including installing a fiberglass insulation gasket on mate wall one half only at each mate wall. (Note: Alternate gasket materials, such as spray foam, may be required for “Energy Star” houses.)
5. Align and secure the modular sections to the foundation as prescribed in Simplex Industries, Inc. “Site Installation Manual”.

6. Install proper fire separation walls when supplied. Apply fire stopping material at all joints in fire rated assemblies as prescribed on the drawings found in the package marked “Set Crew”. (Note: In some cases, the fire stopping material may have to be applied to one half of one module before the module butting to it is set in place.)
7. Align house gable end walls and roof to each other. (May require use of come-along.)
8. Level the floors of Ranches, Cape Cods, and first floor of the Two-Story Models, Shim and bolt or lag or screw the mate wall girder as prescribed in the “Site Installation Manual”. (Note. Review the information in the envelope marked “Set Crew” for additional information.)
9. Install Purchaser provided basement support columns per the “Suggested Foundation Plan” provided to the builder by Simplex Industries, Inc.
10. Ensure roof beams and/or first floor mate wall ceiling bands of Two-Story models have been aligned, shimmed, and bolted or lagged including aligning stairwell walls (1<sup>st</sup>. to 2<sup>nd</sup>. floor), as prescribed in the “Site Installation Manual”. This may require the use of a come-along.
11. As necessary, properly install, secure, and align flip overhangs including sheathing and shingles in a manner consistent with drawing specifications. Refer to the envelope marked “Set Crew” for any specific fastening requirements.
12. Align roof ridge boards, fascia/rake boards and install ridge vent as prescribed in the “Site Installation Manual”.
13. Install ridge vent, ridge vent cap shingles and roof shingles not installed at the factory and/or replace shingles lost in transit. Secure all shingles and sheathing at hinge areas.
14. Install horizontal and vertical sheathing banding pieces and nail in place. (Note: Houses in hurricane prone regions have special fastening requirements for these sheathing panels. Refer to the envelope marked “Set Crew” for these requirements.)
15. Ensure all truss field connections including field applied collar ties are installed and fastened as prescribed on the truss details in the envelope marked “Set Crew” for these specific requirements.
16. Houses may require special fastening and strapping methods. Especially in hurricane prone regions. Refer to the details in the envelope marked “Set Crew” for these specific requirements.
17. All exterior sections must be made sufficiently weather tight to withstand conditions for a minimum period of 14 days, prior to leaving the job site.
18. Clean up all scrap materials and debris resulting from work performed during installation and place in one area on the job site, or in a provided dumpster
19. Stack carriers (no more than 4 high), alternate hitches, and make accessible for pick up.

Any other charges are at the discretion of the Purchaser and the set-up crew, and are not to involve Simplex Industries, Inc. in anyway. It is the Purchaser's responsibility to Inspect and Accept the workmanship of the set crew. The set crews are independent of Simplex Industries, Inc. and they should complete the above Field Installation Work Check List. The only way the set crew can receive payment is by the work release form signed by the Purchaser of his acceptance of the set crew's work along with a copy of the subcontractor's agreement and a liability certificate of insurance from the set crew. The Purchaser is responsible to make certain that the set crew is contracted for all the above items. Failure to do so will result in additional Purchaser site work and costs. Simplex will not take responsibility for items that the set crew does not complete.

**J. TOLERANCES:**

Simplex has established a series of acceptable tolerances regarding module alignment (see exhibit H, Illustrative pages 22 thru 31). The Purchaser should be prepared to perform any adjustments that fall within these tolerances.

**K. UPON COMPLETION OF SET-UP:**

1. The Purchaser is responsible for any damage or theft of SIMPLEX INDUSTRIES, INC. carriers and/or equipment left at the job site. 100% full replacement value costs are required to be paid by Purchaser to Simplex upon the determination by Simplex that carrier is deemed damaged beyond repair or no longer road worthy. It is further understood that Purchaser assumes all responsibility and/or costs related to the removal and disposal of damaged carriers. Carrier deposits are charged on the sales contract/Invoice at \$750.00 per carrier.
2. The Purchaser is responsible for proper carrier stacking and staging in an accessible area for driver hookup and departure from the job site. If SIMPLEX drivers incur any expenses to prepare carriers for return to the factory, any such charges will be billed to the Purchaser. Stack carriers (no more than 4 high), alternate hitches, and make accessible for pick up. Large carriers are to be on the bottom and small carriers stacked on top, right side up and turned backwards in relation to the bottom carrier, providing a 4-foot clearance for the bottom carrier's hitch. When stacking carriers, the tires shall not be permitted to touch each other from one carrier to another.
3. The Purchaser is responsible for proper carrier stacking and staging in an accessible area for driver hookup and departure from the job site. If SIMPLEX drivers incur any expenses to prepare carriers for return to the factory, any such charges will be billed to the Purchaser.
4. Please notify SIMPLEX INDUSTRIES, INC. Transportation Department as soon as the carrier frames are available for pick up.
5. Carrier deposits are generally returned within 14 calendar days of Simplex receiving carrier frames back, in a non-damaged condition and the Field Installation Checklist is returned and completed.
6. Carrier frames used to transport home sections delivered by Simplex must be made available for pick up within (30) thirty-days of the house delivery. Beyond that, a rental fee of twenty-five dollars (\$25.00) per day, per carrier shall be applicable.
7. Use of Simplex carrier frames shall be for the transportation of the assigned Simplex house section serial numbers only. Unauthorized use of Simplex carrier frames for the movement of other homes sections or materials is not allowable. Simplex may initiate legal action against the responsible party in such an event.

**L. POLICY ON PARTS & DAMAGES - UPON DELIVERY:**

1. At the time of delivery ALL homes MUST be inspected by a qualified representative of the Purchaser. Any damages to the home or parts that are either shipped short or damaged MUST be noted on the HOME INSPECTION REPORT for any claims to be honored. If for some reason, any of the above could not be determined at delivery, it must be reported within 5 days after delivery. (Claims made after this period will not be honored.)
2. Replacement items required after the 5-day report period may be purchased from Simplex (if necessary) on a C.O.D. or credit card basis. After availability is determined by the Service Manager you can pick up the items at the plant, with 2 days' notice, or they can be sent to you in the most feasible manner.

**M. DEFECTIVE ITEMS POLICY:**

1. Items supplied by Simplex such as appliances, water heater, shingles, etc., are all covered under their individual manufacturer warranty.
2. Any other claims for replacement of defective items must be submitted to Simplex's Service manager in writing and must include the correct serial number of the home.
  - a. Replacement items will be billed to you on a C.O.D. or credit card basis.
  - b. When the defective item is returned to Simplex, your account will be credited.
  - c. If the defective item is not returned within 30 days of your receiving the replacement item, no credit will be issued.
  - d. After availability is determined by the Service Manager replacement items can be picked up at the plant, with 2 days' notice, or they can be sent to you in the most feasible manner.

**N. SERVICE POLICY:**

All homes are sold to the Purchaser (this is a buyer/seller relationship; not one of agent.) Thus, any complaints or service requests must be submitted by the Purchaser ONLY, NOT THEIR CUSTOMER. Absolutely no request for service or parts under the terms of the warranty will be discussed with retail customers. All calls or correspondence from retail customers will be referred directly to the Purchaser. If a call should get through to our service department, we will politely explain our policy to your customer and instruct them to contact their builder regarding service or parts.

No matter what the situation or contract stipulation the Purchaser has with the Homeowner, it is the Purchaser's responsibility to contact Simplex regarding service or warranty claims. See Manufacturer's Warranty Note: Please refer to your Purchaser's Responsibility sheet before requesting Simplex Service.

1. Requests for factory service must be submitted in writing or by Simplex supplied electronic form by the Purchaser with the following information included
  - a. Serial # of home and type of home
  - b. Purchaser's customer name (if applicable) and address
  - c. Contact person and phone number
  - d. Description of problem(s), please print clearly or type

A verbal request does not constitute an open claim

Note: Email is acceptable provided all the above information is included and can be sent to [service@simplexhomes.com](mailto:service@simplexhomes.com).

2. Upon receipt of the completed paperwork, the Service Manager will review the information and begin processing the request for service and/or parts. If necessary, the service manager will contact the builder by phone, request photographs of a specific problem, or have a factory representative inspect the home in question.



3. All items being requested for factory service must be reported at one time! (Unless it is a structural issue). Simplex will then determine the extent of Simplex's responsibility and schedule service or authorize a Purchaser repair. It is the option of Simplex after determining the legitimacy of the service warranty claim, to have a factory crew, a local subcontractor, or the Purchaser's crew make the repair. Any subsequent service request received after the disposition of the original request will be considered as having occurred due to other than Simplex responsibility.
4. When the service department accepts a claim a copy of the service order will be faxed or e-mailed to the Purchaser no later than 3 days prior to the scheduled service date. The Purchaser must review the service order to ensure that all requested service items are listed and add any additional items (within reason). The Purchaser will then fax or e-mail this back to the Service Department with their signature on it, acknowledging that this is the only work that will be completed during the service.
  - a. The Purchaser, Purchaser's customer or an Authorized representative must be present at the home when the requested service is being performed.
  - b. If the Purchaser or Purchaser's customer cannot be present at the time of the service, they will be required to sign an acknowledgement; agreeing that they will not be present when the service is completed and have until 4:00pm of the following business day to inspect the work and notify Simplex in writing, of any deficiencies. The Purchaser or Purchaser's customer must sign this acknowledgement prior to any work being started by the Service Technician. If the Purchaser or Purchaser's customer refuses to sign this acknowledgement the service technician will not be able to complete the service work and will leave the premise immediately.
  - c. It is the sole responsibility of the Purchaser or the Purchaser's customer to open and lock the premise for Simplex Industries, Inc. service technician and Simplex will not accept any responsibility or liability for opening and entering or closing and locking the Purchaser or Purchaser's customer premise. Further, the Purchaser or the Purchaser's customer will release, acquit, and forever discharge Simplex Industries their successors insurers and assignees from all actions, claims, demands, costs, loss of service, expense, and compensation, on account of or in any way growing out of all known and unknown damages, including loss of any property damaged, resulting or to result from opening or locking the premise by Simplex Service Technician.
5. Remunerations for Service Repair must receive prior approval for a specific and fair dollar amount. If approval is given, a repair authorization number will be assigned and a repair authorization will be sent to you. This original form along with an invoice and a signed acceptance of work done is to be returned to Simplex before payment can be made. Invoices for alleged warranty repairs, which did not receive a repair authorization, will be denied.
6. We encourage the Purchaser to submit photographs when requesting Service or Remuneration. This will help identify the cause and course of action to repair.
7. Items not covered under warranty.
  - a. No claims will be honored due to shadow and tint variations on interior walls and ceilings in paint caused by touching up areas of the primer coat.
  - b. No claims will be honored due to excessive humidity or vapors caused by misuse of exhaust fans and/or portable heating unit(s).
  - c. No claims will be honored due to condensation caused by extreme temperature differences.
  - d. No claims will be honored due to malfunctions caused by the Purchaser's finishing, or not completing the construction of the building.

**O. BUILDER/PURCHASER RESPONSIBILITIES:**

<b>Design &amp; Project Management</b>	<u>Simplex</u>	<u>Purchaser</u>	
Architect/Engineer of Record/Builder of Record		X	
Energy Star/Green Building/ LEED Certification Determination		X	Inform Manufacturer of Requirements
Code Analysis and Review		X	Including Local Code Requirements.
Design - Architectural		X	
Design - Civil		X	
Drafting Services	X		To achieve state approved plans
Design/Architectural		X	
Design - Foundation/Site Built Structures(s)		X	
Design - MEP Systems		X	
Design - Fire Protection		X	
Modular Plan Approval - State	X		
Plan Approval - Local		X	
Licensing Requirements - Local Contractors		X	Inform Manufacturer of Requirements
Shop Drawings	X	X	Drawn by Manufacturer, approved for construction by purchaser
<b>Administrative</b>	<u>Simplex</u>	<u>Purchaser</u>	
Site Plan/Survey Information		X	Site Survey, Measured Drawing Information, Photographic Information. Site Plan required by the third-party reviewer for plan approval.
Environmental Assessment Information		X	
Permit Applications		X	All Required Permits
Deposits, Payment & Performance		X	Refer to General Information and Polices
Contract/Sales Agreement w/Attachments	X		Refer to Retail Acknowledgement, Photo Release, Notice to Proceed, and any other documents required by Manufacturer
Prevailing Wage or Union Wage		X	Purchaser agrees that the pricing contained in the Sales Contract does not include any prevailing wage or union wages either at the plant or on site for any service work or site services provided. If the manufacturer is required to comply with either union scale or prevailing wage scales in the field or in the manufacturing process, then the pricing set forth shall be modified to include any additional costs for said wages and/or benefits
Project Management		X	
Site Supervision		X	
Specifications - Modular Units	X	X	Shared Responsibility
Specifications - Site Construction		X	
Project Scope	X	X	Shared Responsibility, Refer to General Information and Polices and Sales Contract
Project Schedule		X	
Change Order Issuance & Control	X		Refer to General Information and Polices and Sales Contract
Simplex Builder Application	X	X	Supplied by Simplex, Completed by Purchaser
Payment of Modules		X	Refer to General Information and Polices and Sales Contract
<b>General Requirements</b>	<u>Simplex</u>	<u>Purchaser</u>	
Debris Dumpsters & waste Removal		X	
Security - Project Site		X	Including fencing if required.
Security - Storage Site		X	Including fencing if required.
Temporary Barriers & Enclosures		X	
Insurance - Builder's/All risk		X	

<b>General Requirements (continued)</b>	<b>Simplex</b>	<b>Purchaser</b>	
Insurance - During Module Delivery	X	X	Transportation company to supply insurance
Insurance - During Local Storage		X	
Insurance - During Module Erection		X	When module is connected to crane's hook until crane cables are released. Crane and Set Crew Insurance Certificates required, refer to Builder Policies
Insurance - After Module Erection		X	From the time the crane's cables are released
Modular Unit Storage - Local		X	Must be un-restricted, level, hard packed surface capable of storing the modular units. If an on-site storage area is not possible, Purchaser shall provide an off-site storage area. Recommended to be within 2 miles of project site.
Survey - Site/Building Location		X	
Access - Project Site		X	
Weather Protection		X	After Delivery is completed, it is the purchaser's responsibility to inspect and if necessary, protect the modules from adverse weather conditions
<b>Civil Work</b>	<b><u>Simplex</u></b>	<b><u>Purchaser</u></b>	
Clearing		X	
Permits & Fees		X	Including Utility Tap Fees
Demolition & Hauling		X	
Building Excavation & Backfill		X	To be completed prior to module installation.
Utility Trenching & Backfill		X	To be completed prior to module installation.
Overburden Hauling, Removal of Excess Material and Waste		X	To be completed prior to module installation.
Rough Grading		X	To be completed prior to module installation.
Crane Pad Preparation		X	To be completed prior to module installation.
Foundation Drainage Including Receptors for Roof Drain Leaders		X	Including but not limited to Sub-Slab, Footer, Sump
Bring all Utilities through Foundation Wall		X	Including Sprinkler Main
Sprinkler System	X	X	Refer to Simplex's plans and scope of work for specific responsibilities when required
Site Preparation to Enable Delivery		X	See General Information and Policies
<b>Foundation</b>	<b><u>Simplex</u></b>	<b><u>Purchaser</u></b>	
Foundation/Modular Structure Support		X	Including Footings, Grade Beams, Piles, Piers & Walls. Top of platform maximum dimensional tolerance of any length, width, or diagonal dimension shall be 1/2". Maximum elevation tolerance of the foundation sill or bearing plated shall be +/- 1/8".
Foundation Damp Proofing		X	
Foundation Dewatering		X	Prior to module installation.
Module Bearing/Sill Plates and Sill Sealer		X	
Structural Anchors Embedded into Foundation and/or Anchored to Steel Support Members		X	Attached to Foundation/Steel Supports by Party Providing Foundation/Steel Supports. Attachments to modular units is usually done by the set crew or site contractor. Strapping & hold-downs for all module-to-foundation connections to be provided and installed and connected on-site by purchaser
Steel Beams, Columns and Associated Fire Protection		X	Including basement support columns, where applicable.
Concrete Flatwork		X	Including Basement Slab, Crawl Space slab, Patio Slabs, driveway, sidewalks etc.

<b>Module Transportation</b>	<b>Simplex</b>	<b>Purchaser</b>	
Police escorts and Escort cars, as needed.	X	X	Arranged by Simplex and paid by purchaser
Delivery to Initial Delivery Site Including Permits	X	X	Transportation company
Shuttle from Off-Site Storage Site including Transit Permits & Police Escorts and Escort Cars, where necessary.		X	Manufacturer to provide "alternative" pricing, if necessary.
<b>Module Installation</b>	<b>Simplex</b>	<b>Purchaser</b>	
Administrative-Street/Sidewalk closings		X	
Inspection Fees		X	
Coordinate All Required Inspections		X	
Module Installation-Removal of Transit Wrap/Preparation for Installation		X	Refer to General Requirements for Dumpster Provisions.
Module Installation-Crane Rental		X	Including Permits
Module Installation-Place Module Units on Foundation or Another Module Unit		X	Usually performed by the set crew
Set Crew		X	Hire and arrange all scheduling and payment of installation crew
Module Installation-Level Floors		X	Repair or replace broken or damaged floor joists due to off road transit damage
Flat Roofs or Low Pitch Roofs-Completion of Sheet Membrane Roofing Systems		X	Including Roof Sheathing hold-backs & roof coverings. See Exterior Finish for Mansard & Other Finishes Beyond the Scope of Main Roof Coverings.
Flat Roofs or Low Pitch Roofs-Install Temporary Roof Drainage Piping to Storm Water System		X	Low Pitch Roofs with internal or external Drains
Flat Roofs or Low Pitch Roofs-Equipment & Duct Support Curb Extensions		X	See Modular Unit Specifications for roof/support/curbs provide from the factory.
Parapet Roof-Install Components & Braces		X	Including Completion of Roof Terminations on inner surface & removal of temporary termination bars installed at factory
Parapets-Completion of Sheathing(s) & Temporary Roof Cap		X	
Pitched Roof-Roof Coverings		X	Including Drip Edge, underlayment & attic ventilation products. Replace shingles lost in transit
Shingles are to be nailed at all hinged areas after the roof has been raised, shingles are to be installed in all other areas as required to make the home weather tight. Ridge vent must also be installed		X	
Replace any shingles lost in transit		X	
Pitched Roof-Eave Build out at Eave Intersections		X	
Roof Plumbing Vent Penetrations, Flashings and Extensions		X	
Roof or Exterior Wall Ventilation Caps for HVAC, Fans, Dryers		X	Including Vent extensions, where applicable
Install Porches, Dormers, Columns, Special Parts		X	Including collar ties where applicable
Flip overhangs, when used, must be properly fastened, and aligned, while allowing for the proper ventilation		X	
Any on site modifications requiring additional ventilation must be provided by the Purchaser. The Purchaser must provide any on site modification requiring additional ventilation		X	
Dormers must be completed on-site, pull-down dormer, cape, shed panelize, etc.		X	
Install collar ties where applicable (7/12, 9/12 and 12/12 pitch roofs)		X	
Temporary Weather Protection		X	Make house weather tight
Structural Connections- Module to Foundation & Module to Module		X	Strapping and hold-downs for all module-to-module connections to be provided and shipped loose by Simplex for on-site connection by set crew

<b>Module Installation (continued)</b>	<b>Simplex</b>	<b>Purchaser</b>	
Direct Set Crew to seal the exterior of the home, during the set, in order to comply with the 2012,2015,2018 IECC, Energy Star, Stretch Code or any other codes pertaining to the location they are building in. Including but not limited to Foam Seal Gasket or spray foam insulation at Module Mating Walls, caulking or taping field applied sheathing or bands between first and second floor boxes on multi story homes.		X	Required
Install Exterior Sheathing(s) Where Held Back at Module Mating Points		X	Including Roof Sheathing(s), Where Applicable
Install Exterior Air/Vapor Barrier(s) Where Held Back at Module Mating Points		X	Tape when required
Floor Insulation		X	Floor insulation is to be purchased and installed to conform to code. If installed by manufacturer, replace if missing or wet from transportation
Construction Cleanup		X	
<b>Exterior Finish</b>	<b>Simplex</b>	<b>Purchaser</b>	
Exterior Skin - Temporary Weather Protection		X	Maintain Exterior Protection initially installed by Manufacturer.
Exterior Skin - Shimming		X	Providing Shimming of Exterior Face from module-to-module for alignment prior to application of Exterior finish/skin. Adjustment of 3/8" +/- module to module can be expected and Purchaser is responsible to design into their exterior finishes expansion and contraction control.
Exterior Skin - Flashings & Sealants Exterior Finish/Skin		X	Refer to Module Unit Specifications for "all" factory installed flashings & sealants. Ensure all penetration through exterior skin are properly flashed/sealed. Including, Trim, Accessories, Decorative Columns, Louvers, etc. Provide All Required Staging.
Install gable end siding and trim, the first course or siding on the front and rear of the home and install all other un-installed siding soffit, fascia, windows, and shutters as required		X	
Exterior Skin- HVAC, Fan, Dryers Vent Terminations		X	Provide & install all HVAC vent caps & terminations.
Exterior Light Fixtures		X	Install
Pitched Roof- Eave/Overhang Finishes		X	Install
Pitched Roof- Gutters, Downspouts & Splash Blocks		X	
Parapet - Cornice Trim Details & Finish Cap		X	
Roof-Electrical Whip Terminations		X	
Garage-Overhead Door Build Down		X	
Garage-Overhead door, Hardware & Opener		X	Including Interior Framing Attachments
Exterior- Finish Painting		X	
Windows & Exterior Doors- Clean Weep Hole and Tracks of Construction Debris		X	Refer to Modular Unit Specifications for screens provided/ shipped loose from Manufacturer's factory.
Windows and Exterior Doors- Install Window/ Door Screens		X	
Ship loose Windows		X	Install ship loose windows
Exterior Doors and Patio Doors		X	Re-set, plumb and insulate all exterior doors and patio doors
<b>Plumbing Domestic Water</b>	<b>Simplex</b>	<b>Purchaser</b>	
Permits		X	
Inspection Coordination		X	
Inspection Fees		X	
Water Service Brought into Building Envelope		X	
Water Meter(s)		X	
Connections to water heating units		X	Water heater must be filled prior to turning on power
Connections Between Modular units		X	Material not supplied by Simplex

<b>Plumbing Domestic Water (continued)</b>	<b><u>Simplex</u></b>	<b><u>Purchaser</u></b>	
Inspection, Adjustment & Tightening of All Threaded Fittings/Connections or crimping of water lines, which may have worked Loose During Transit		X	
System Testing & Trouble-Shooting		X	Pressure test system after completion and make minor repairs if necessary
Minor Plumbing Repairs		X	
Adjustment of Faucet Valve Temperature Controls, toilet flow valves and trip levers		X	
<b>Drain, Waste &amp; Vent</b>	<b><u>Simplex</u></b>	<b><u>Purchaser</u></b>	
Permits		X	
Inspection Coordination		X	
Inspection Fees		X	
Sewer Brought into Building Envelope		X	
Entire System from Interior Building Envelope & Distributed throughout Modular Building Components in Crawl Space or Basement		X	Refer to Modular Unit Specifications for screens provided/ shipped loose from Manufacturer's factory.
Connections Between Modular units		X	Material not supplied by Simplex
Inspection, Adjustment & Tightening of All Threaded Fittings/Connections or re-crimping of water lines Which may have worked Loose During Transit		X	
Vents through Roof		X	
System Testing & Trouble-Shooting		X	Pressure test system after completion and make minor repairs if necessary
Minor Repairs		X	
<b>Storm Water System(s)</b>	<b><u>Simplex</u></b>	<b><u>Purchaser</u></b>	
Permanent Roof Drain Leaders and Gutters		X	
<b>Fuel Delivery System Gas Lines</b>	<b><u>Simplex</u></b>	<b><u>Purchaser</u></b>	
Permits		X	
Inspection Coordination		X	
Inspection Fees		X	
Fuel Delivery System Brought into Building Envelope		X	
Piping Connections Within and Between Modular Units		X	
Inspection, Adjustment & Tightening of All Threaded Fittings/Connections		X	
Final Connections to Equipment		X	
Testing & Trouble-Shooting		X	
<b>Fire/Hazard Detection Fire Suppression System</b>	<b><u>Simplex</u></b>	<b><u>Purchaser</u></b>	
Permits		X	
Inspection Coordination		X	
Inspection Fees		X	
Water Service Brought into Building Envelope		X	
Fire Suppression System for Entire Building	X	X	Possible shared responsibilities
Connections Between Modular units		X	
Inspection, Adjustment & Tightening of All Threaded Fittings/Connections Which may have worked Loose During Transit		X	
Testing & Trouble-Shooting		X	
System Repairs		X	
Booster Pump		X	
<b>Electrical Systems (Line Voltage)</b>	<b><u>Simplex</u></b>	<b><u>Purchaser</u></b>	
Permits		X	
Inspection Coordination		X	
Inspection Fees		X	
Electrical Service brought from Street to Meter Base		X	

<b>Electrical Systems (Line Voltage) (Continued)</b>	<b><u>Simplex</u></b>	<b><u>Purchaser</u></b>	
Electrical Meter Base, Mast and Service Cable to Panel Box		X	Including service disconnect as required by code
Electrical Meter(s)		X	
Electrical Service Switchgear, Grounding, Drop-Down Transformers Servicing Site Built Spaces		X	
Interconnect electrical between modules including first and second floor		X	
Entire System Distributed Throughout Site Built Components		X	
Conduit and/or Circuit Connections Between Modular Units		X	Material not supplied by Simplex
Entire System Distributed Throughout Modular Building Components and Test to appropriate code		X	Refer to Modular Unit Specifications for system components provided by Manufacturer in factory
Provide & Install all Light Bulbs		X	
Install Light Trims/Shade/Globes Including Light Fixtures Provided by Manufacturer in Factory.		X	
Complete Installation of Electrical Device Cover plates		X	If Not Installed
Testing & Trouble-Shooting		X	
Minor System Repairs		X	
<b>Telecommunications Systems</b>	<b><u>Simplex</u></b>	<b><u>Purchaser</u></b>	
Service(s)) Brought from street to Backer Board Inside Building Envelope		X	
Service Backer Board		X	
Entire System Distributed Throughout Site Built Components		X	
Conduit and/or Circuit Connections Between Units		X	
Entire System Distributed Throughout Modular Building Components	X	X	Refer to Modular Unit Specifications for system components provided by Manufacturer in factory. Possible shared preparation
Minor System Repair		X	
Testing & Trouble-Shooting		X	
<b>HVAC</b>	<b><u>Simplex</u></b>	<b><u>Purchaser</u></b>	
Permits		X	
Inspection Coordination		X	
Inspection Fees		X	
HVAC Equipment Service Contracts		X	Entire Building
Entire System(s) for Site Built Components		X	Including related rooftop equipment
Entire System for Modular Building Components	X	X	Possible shared preparation, Refer to Simplex Sales Contract for Specific Scope Between Manufacturer and Purchaser
Connections Between Modular units		X	Material not supplied by Simplex
System Startup and Balancing		X	
Testing & Trouble-Shooting		X	
Minor system Repairs		X	
Vent Terminations & Caps at Exterior Walls		X	
Vent Terminations & Caps at Roof		X	
Flu Pipe		X	Complete all flu pipe connections as required by flu manufacturer and State/Local building codes
Furnaces		X	Furnace will be shipped loose, if ordered. No electrical or mechanical hook ups or materials will be supplied by Simplex

<b>Site Interior Finish Finishes</b>	<b>Simplex</b>	<b>Purchaser</b>	
Inspect, Inventory and Secure all Materials Shipped Loose by Manufacturer from Factory.		X	
Remove Temporary Shipping Braces		X	
Cut and/or Shim Mate Wall Opening for Alignment		X	
Install Draft Stopping Material at Perimeter of Mate Wall Openings		X	
Install Metal Strapping at Mate Wall Openings		X	
Install Balance of Drywall at Mate Wall Ceiling & wall Holdbacks.		X	Provide & Install corner bead material, joint tape & compound as needed.
Repair All transit Cracks and/or Fastener Pops imperfections or visible seams in Drywall		X	Inclusive of Material and Labor
Build visual standard for drywall inspections		X	Inspection lighting should be representative of normal lighting conditions in intensity and location. Consider the effects of window treatments and other decorative finishes that could affect lighting and viewing. A normal viewing position should be used for the inspection. This is defined as a viewing position at any angle provided it is established at a minimum distance of six feet perpendicular from the surface to be inspected. The inspection evaluation is the conducted without magnification, with normal lighting from the normal viewing position. These guidelines have been derived from National Association of Home Builders (NAHB)
Prime Paint Field Installed Gypsum Wallboard and Field Repairs		X	Material Shipped Loose from Factory
Install Floor Decking and Underlayment at Mate Wall Holdbacks. Repair or replace broken floor joists due to off road transit damage		X	Material Shipped Loose from factory
Close Off All Temporary Accesses in Floor, Walls and/or Ceilings		X	Upon Completion& Inspection of Structural and/or MEP Connections
Adjust Windows as Required		X	
Site Expansion Joints as Required		X	Expansion Joints are recommended with in flooring and gypsum panels at the connection areas
Inspect All Factory Installed Doors for Operation. Adjust as Needed.		X	
Install Doors, Hardware, Casing, and Intersecting Base at Mate Wall Openings		X	Material Shipped Loose from Factory
Install Door Stops Where Shipped Loose from Factory		X	Material Shipped Loosely from Factory to Prevent damage to door panels in transit
Install any Closet Shelving when Shipped Loose from Factory at Mate Wall Openings		X	
Install Cabinet Shelving & Clips. Adjust as Desired		X	
Review and Adjust Cabinetry Doors as Needed for Alignment		X	
Install Toilet Tank Lids		X	
Install Tub/Shower Enclosures if Specified and Supplied		X	
Adjust Caulk and/or Putty All Trim, Countertops and Fixtures as desired.		X	Inclusive of materials and Labor
Repair miscellaneous floor squeaks and bridging in floor joists as required		X	
Final Painting/Staining		X	Walls, Ceilings, Doors, Trim, Stairs, Railings, etc.
Complete Installation of Factory Provided Floor Covering(s) at Mate Wall Holdbacks		X	Including stair carpeting. Ceramic Tile, Hardwood or Laminate Flooring



<b>Site Interior Finish Finishes (continued)</b>	<b><u>Simplex</u></b>	<b><u>Purchaser</u></b>	
Restretch Carpet and Repair Seams as Required		X	
Provide & Install Floor Coverings not Installed or Provided by Manufacturer		X	
Un-Package and Install Appliances Shipped loose by manufacturer from the Factory.		X	Adjust handing of refrigerator if required and supply and install range cord
Broom/Cleaning/ Construction Cleaning		X	Area(s) included in Scope of Work.
Install Basement Stairs (not supplied by Simplex)		X	
Install Interior Stairs and Railings on Some Models		X	
Provide and Install all Appliances not Provided by the Manufacturer.		X	
<b>Miscellaneous</b>	<b><u>Simplex</u></b>	<b><u>Purchaser</u></b>	
Elevator System(s)		X	
<b>Project Close Out</b>	<b><u>Simplex</u></b>	<b><u>Purchaser</u></b>	
Contractor Punch-Out		X	
Explanation of Building Warranty and Service		X	
O&M Manuals if Required		X	

Notes:

1. This work is all inclusive. Some work may not be applicable to your project. Consult your Account Manager
2. Work Listed as "Manufacturer's" Responsibility shall be limited to spaces and/or work provided by the Manufacturer
3. Not all work identified in this Project Scope will be required in the final building design. Therefore responsibility for work indicated shall only be applicable if the Scope of work exists in the final building design.

**P. ENGINEERING FEE SCHEDULE:**

**SIMPLEX INDUSTRIES, INC.  
PRINT AND CALCULATION SERVICES  
PRICE GUIDE  
Effective April 19, 2021**

Simplex Industries standard engineering services will be formatted to fit on 11X17 paper electronically delivered to you or a printing shop of your choice. **There will be additional costs for paper copies, larger sized copies and additional copies as well as actual shipping related expenses.**

3/16" Scaled on 11X17 paper (each)	\$35.00 per Set
18 X 24 Prints (each)	\$65.00 per Set
24 X 36 Prints (each)	\$80.00 per Set

Effective April 19, 2021, Simplex Industries will require a credit card to be placed on file with our accounting department for all preliminary print expenses. An initial charge of \$350.00 for preliminary prints will be made when the drawing request is accepted by the engineering department. The first drawing revision is free of charge, any additional drawing revisions that are required due to changes made after the 1<sup>st</sup> revision will be charged at \$100.00 per complete drawing revision. By having the card kept on file to cover any related costs to revisions that are made after the 1<sup>st</sup> free revision the process can continue without delay and not require waiting until additional fees are received. If you do not place a credit card on file, preliminary floor plan designs will require a deposit of \$550.00 to cover the initial fee and 3 total revisions (no refunds). Any additional revisions after the 3<sup>rd</sup> revision will require prepayment before it can be completed.

Costs below are the fees for print design and production services.

**Services Required**

**Electronic Copies**

**Simplex print services for floor plan and elevation design** (include 1 plan revision at no additional charge). **Any modification made after the 1<sup>st</sup> plan revision will be charged \$100.00 for each additional time the plan is revised.**

<b>Preliminary floor plan with front elevation</b> *(includes 1 plan revision)	\$ 350.00
(Any modification made after the 1 <sup>st</sup> revision will be charged \$100.00 for each additional time the plan is revised)	
<b>Preliminary floor plan with electrical plan</b> (in addition to the initial \$350.00)	\$ 100.00
<b>Preliminary floor plan with suggested foundation print</b> (in addition to the initial \$350.00)	\$ 100.00
(No load calcs performed)	

**\*Full set of permit drawings with stamp** (up to 4 modules) \$2,150.00  
Includes 5 hours of structural engineering services and kitchen perspective drawing (1 kitchen perspective drawing change allowed) Some complex home designs may require more structural engineering time, additional costs for these services will be billed in accordance to our hourly rate fee listed below.

**\*New York State –Full set of permit drawings with stamp** \$2,250.00  
(Up to 4 modules) includes 5 hours of structural engineering services, includes kitchen perspective (1 kitchen perspective drawing change allowed) Some complex home designs may require more structural engineering time, additional costs for these services will be billed in accordance to our hourly rate fee listed below.

**Special full set of permit drawings with or without stamp** \$ Quote  
Required

**Additional kitchen perspective drawing revisions** \$ 200.00  
**Structural engineering services** (beyond the standard 5 hours allowed) \$ 200.00/hr.

Please Note: All print and calculation fees are non-refundable

\*Simplex reserves the right to adjust any of the above added costs if the complexity of the drawing project exceeds the time frame allowed to complete the project.

**Q. PERMIT FEES:**

**FOR EACH TRUCK/MODULAR BOX ARE AS FOLLOWS:**

<u>STATE</u>	<u>SIZE (WIDTH)</u>	<u>BUILDER COST</u>	<u>NOTES</u>
PENNSYLVANIA	11' 6" - 14' 5"	\$50.00	
PENNSYLVANIA	14' 6" - 16' 0"	\$100.00	
PHILADELPHIA	8' 1" - 16' 0"	\$100.00	
NEW JERSEY	8' 7" - 14' 0"	\$55.00	
NEW JERSEY	14' 1" - 16' 0"	\$150.00	
NEW YORK	11' 0" - 14' 0"	\$90.00	
NEW YORK	14' 1" - 16' 0"	\$125.00	SURVEY NEEDED OVER 14' 0" WIDE OR 14' 0" HIGH / FLAG CAR RATE PER MILE
NEW YORK CITY	10' 0" - 14' 0"	\$120.00	
NEW YORK CITY	14' 1" - 16' 0"	\$140.00	GEO-METRIC SURVEY NEEDED (\$2500.00) / 30 DAYS PRIOR
NY (NASSAU COUNTY)	10' 0" - 14' 0"	\$205.00	
NY (NASSAU COUNTY)	14' 1" - 16' 0"	\$205.00	
NY (SUFFOLK COUNTY)	10' 0" - 14' 0"	\$100.00	
NY (SUFFOLK COUNTY)	14' 1" - 16' 0"	\$100.00	
CONNECTICUT	8' 7" - 14' 0"	\$70.00	
CONNECTICUT	14' 1" - 16' 0"	\$200.00	PILOT PROGRAM RULES APPLY / NIGHT TRAVEL
MASSACHUSETTS	8' 7" - 13' 11"	\$80.00	
MASSACHUSETTS	14' - 15' 11"	\$350.00	
RHODE ISLAND	8' 7" - 13' 11"	\$55.00	
RHODE ISLAND	14' - 15' 11"	\$200.00	
VERMONT	8' 7" - 16' 0"	\$75.00	
NEW HAMPSHIRE	8' 7" - 16' 0"	\$50.00	
MAINE	8' 7" - 16' 0"	\$55.00	
MARYLAND	8' 7" - 16' 0"	\$60.00	
DELAWARE	8' 7" - 14' 11"	\$65.00	
DELAWARE	15' 0" - 16' 0"	\$95.00	
WEST VIRGINIA	8' 7" - 16' 0"	\$75.00	
VIRGINIA	8' 7" - 16' 0"	\$75.00	

**R. STATE SEALS:**

<b>STATE SEALS</b>	<b>(Per 2 modules)</b>	<b>EACH ADDITIONAL MODULE</b>
CT	\$200.00	\$ 60.00
DE	\$155.00	\$ 60.00
GA	\$400.00	\$200.00
ME	\$550.00	\$110.00
MD	\$420.00	\$ 110.00
MA	\$375.00	\$ 110.00
NH	\$295.00	\$110.00
NJ	\$375.00	\$180.00
NY	\$375.00	\$120.00
NC	\$300.00	\$ 90.00
PA	\$275.00	\$100.00
RI	\$375.00	\$180.00
VT	\$220.00	\$ 60.00
VA	\$300.00	\$ 60.00
WV	\$150.00	\$ 60.00
DC	\$300.00	\$100.00
SC	\$300.00	\$100.00

- **PLEASE NOTE: The above costs are per dwelling unit. You must take above costs and multiply it by the number of dwelling units for your total costs of State Seals.**

**P. INSURANCE REQUIREMENTS:**

Risk of loss, including but not limited to fire, vandalism, theft, malicious mischief, extended risk, or any other hazard, shall pass to Purchaser upon tender of delivery to the job site or staging area or on the thirtieth (30<sup>th</sup>) day after the unit(s) are off the Manufacturer's production line and not delivered to Purchaser's job site or staging area. Purchaser is required to provide insurance coverage for unit(s). Purchaser shall indemnify, defend, and hold Manufacturer harmless from and against any loss to the unit(s), or caused by the unit(s), or by any action upon the unit(s), thereafter. This insurance must cover the unit(s) for occurrences including, but not limited to, losses for theft, fire, vandalism, acts of nature, and Acts of God. Purchaser acknowledges that the below insurance schedule outlines which party in this transaction is responsible for providing coverages throughout the transaction, and that it is their sole responsibility to secure and provide coverage for the unit(s) during the timeframes described below:

- At the Manufacturing Facility – Manufacturer
- Transporting to Job Site or Staging Area - Transportation Company
- The Thirtieth (30<sup>th</sup>) Day After the Unit(s) are Off the Manufacturer's Production Line and Not Delivered - Purchaser
- Upon Arrival to Job Site or Staging Area – Purchaser
- During Installation of the Unit(s) – Purchaser
- Once Unit(s) are Installed Upon the Foundation – Purchaser

Manufacturer bears no responsibility, financial or otherwise for any damages occurring during these periods other than when at its Manufacturing Facility. On a rare occasion when the unit(s) are not paid for and the unit(s) are not at the Manufacturing Facility, or the thirtieth (30<sup>th</sup>) day after the unit(s) are off the Manufacturer's production line has passed and the unit(s) not delivered to Purchaser's job site or staging area, the Purchaser will obtain a special perils builder's risk policy naming the Manufacturer as a named insured for the unit(s), and to include a waiver of subrogation in favor of Manufacturer. Purchaser shall provide Manufacturer with a copy of a certificate of insurance showing Manufacturer as "Loss Payee" for a dollar amount equal to the price of any unit(s) delivered, but not paid in full. Additionally, Purchaser will also provide proof of liability insurance, renewable on an annual basis, and shall inform Manufacturer immediately upon any change in insurance status. Purchaser shall name Manufacturer as additional insured and the certificate of insurance provided shall detail the additional insured information. Manufacturer's minimum insurance requirements for Purchaser, along with sample Certificate of Insurance attached.

## Exhibit A

### Simplex Industries, Inc. Minimum Insurance Requirements

Please forward the requirements below to your insurance agent. Prior to serial numbering an order from an Independent Builder, Simplex Industries, Inc. requires Independent Builder to provide evidence of current insurance by providing a current Certificate of Insurance. Sample Certificate of Insurance is included for reference. As an Independent Builder, you shall cause each of your subcontractors to comply with the requirements set forth in this insurance schedule. Any reference to "Independent Builder" herein is intended to include Independent Builder and its subcontractors.

Independent Builder shall, at its own expense, always maintain during the term of the Agreement, the following identified insurance, each written by insurers in good standing and qualified to do business in each jurisdiction where the work is performed.

<b>COMMERCIAL GENERAL LIABILITY - AM BEST RATING OF A- AND FSC VII OR BETTER</b>	
<b>COVERAGE</b>	<b>REQUIRED LIMIT</b>
Each Occurrence	\$1,000,000
Personal & Adv Injury	\$1,000,000
General Aggregate	\$2,000,000
Product - Comp/Op	\$2,000,000
<b>General Liability to be provided in form no less broad than a standard ISO CG 00 01</b>	

<b>AUTOMOTIVE LIABILITY - AM BEST RATING OF A- AND FSC VII OR BETTER</b>	
<b>COVERAGE</b>	<b>REQUIRED LIMIT</b>
All Owned, Hired and Non-Owned Autos	
Combined Single Limit Bodily Injury and Property Damage	\$1,000,000

<b>UMBRELLA LIABILITY - AM BEST RATING OF A- AND FSC VII OR BETTER</b>	
<b>COVERAGE</b>	<b>REQUIRED LIMIT</b>
Each Occurrence	\$1,000,000
Aggregate	\$1,000,000

<b>WORKERS COMPENSATION/EMPLOYER LIABILITY - AM BEST RATING OF A- AND FSC VII OR BETTER</b>	
<b>COVERAGE</b>	<b>REQUIRED LIMIT</b>
Workers Compensation	Statutory Limits
Employer's Liability Each Accident	\$500,000
Employer's Liability Each Disease - Each Employee	\$500,000
Employer's Liability Disease Policy Limit	\$500,000

#### CERTIFICATE HOLDER

Certificate holder must list:  
Simplex Industries, Inc.  
1 Simplex Drive  
Scranton, PA 18504

## Simplex Industries, Inc. Minimum Insurance Requirements (cont)

### ADDITIONAL INSURANCE REQUIREMENTS

- Simplex Industries, Inc. and its subsidiary companies, its officers, directors, partners, representatives, agents, and employees must be added as additional insureds on general, umbrella and automobile liability policies per the below provisions.
  - a. Simplex Industries, Inc., and its subsidiary companies, its officers, directors, partners, representatives, agents, and employees shall be named as additional insureds for ongoing operations and products/completed operations on Independent Builder's Commercial Liability policy and Umbrella/Excess policy, which must be primary and noncontributory with respect to these additional insureds. The insurance shall remain in effect as for a period consistent with the applicable State and Local jurisdiction statute requirements.
  - b. Simplex Industries, Inc., and its subsidiary companies, its officers, directors, partners, representatives, agents, and employees shall be named as additional insureds on the commercial automobile liability policy, which must be primary and noncontributory with respect to the additional insureds.
- Waiver of Subrogation in favor of Simplex Industries, Inc., and its subsidiary companies, its officers, directors, partners, representatives, agents and employees under the General Liability, Automobile and Worker Compensation policies where permissible by law.
- Policies must be primary and non-contributory.
- An AM best rating of A- and FSC class of VII or better is required on all insurance carriers.
- The identified Insurance shall also:
  - a. Require Simplex Industries, Inc., to be notified in writing at least thirty (30) days prior to cancellation of, or any material change in, the policy.
  - b. In the case of policies or provisions relating to products, completed operations and professional liability, survive termination or expiration of the Agreement.
- Independent Builder shall furnish to Simplex Industries, Inc. upon request, certificates of insurance (on a form acceptable to Simplex Industries, Inc. evidencing all identified insurance and, at least thirty (30) days prior to the expiration of a policy, certificates evidencing additional or renewal policies. Copies of additional insured endorsements, waiver of subrogation endorsements and cancellation endorsements shall be attached to the certificate of insurance.
- All identified insurance shall be written on an occurrence basis except for Independent Builder's professional liability (if required), which may be written on a claims-made basis. Any deductibles or self-insured retentions shall be the sole responsibility of Independent Builder, and coverage shall apply for the benefit of Simplex Industries, Inc., and all additional insureds as if no deductible or self-insured retention applied.
- To the fullest extent allowed by law, Independent Builder hereby waives all rights of recovery in favor of the Additional Insured and the Indemnities.
- Independent Builder shall bear the risk of loss with respect to any owned, leased, rented, or borrowed vehicles, equipment, data, tools, or other personal property. Independent Builder shall bear the risk of loss with respect to any of its expenses or loss of income.

### ADDITIONAL REQUIRED DOCUMENTS

- Declaration of Contractual Agreement
- W-9 Tax Form (version date must be the most current version and must be signed within the past 12 months to be compliant).

**The required limits of insurance are subject to change based on the total amount of each individual project.**

REFERENCE NEXT PAGE FOR SAMPLE CERTIFICATE OF LIABILITY INSURANCE



# EXHIBIT "H"

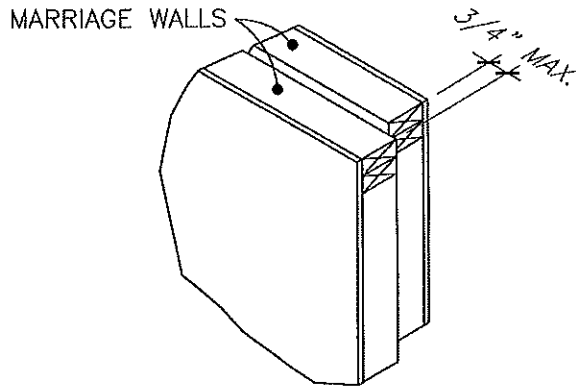
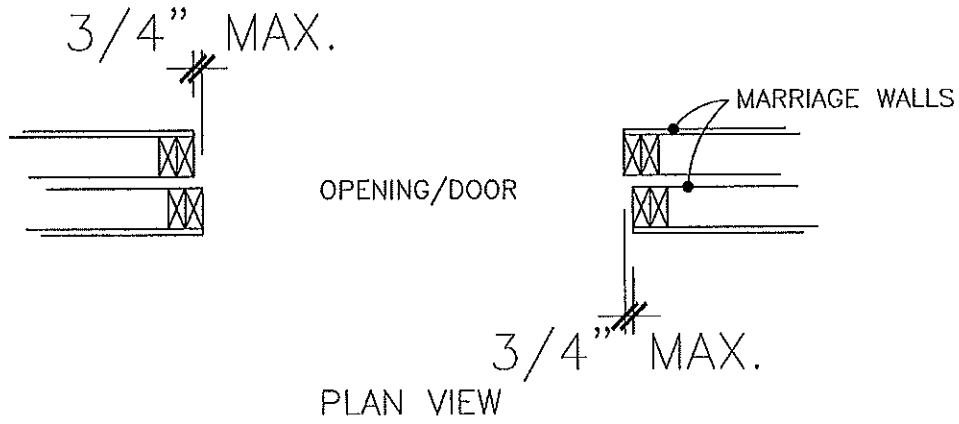

ISOMETERIC

SAME UNIT



MODULAR TOLERANCES - MARRIAGE WALLS

Drawn By: CIC
Scale: NONE
Date: May 21, 2007
Revisions: July 31, 2017

SK-A



# EXHIBIT "H"

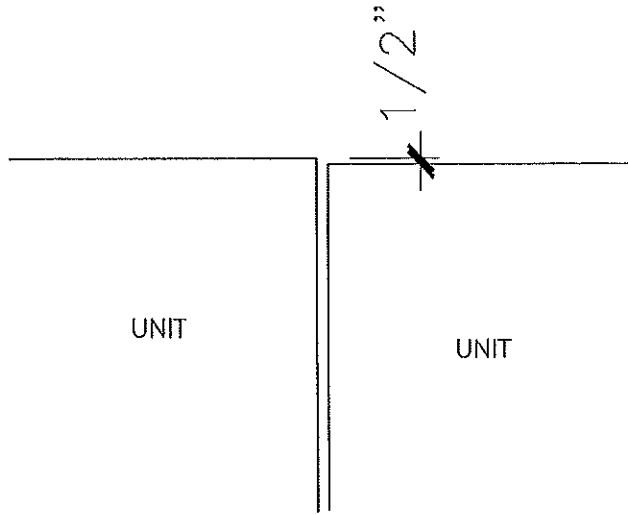

PLAN VIEW

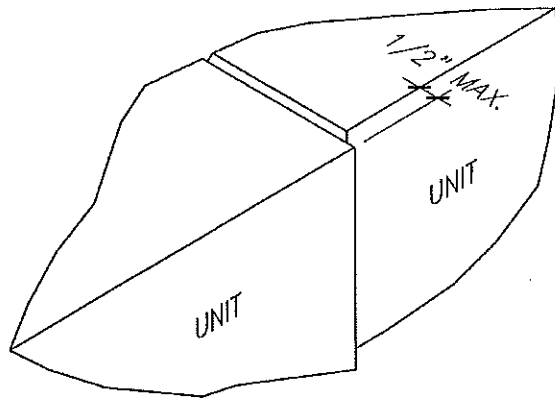

ISOMETRIC



MODULAR TOLERANCES –  
HORIZONTAL BETWEEN UNITS

Drawn By: CIC

Scale: NONE

Date: May 21, 2007

Revisions: July 31, 2017

SK-B

# EXHIBIT "H"

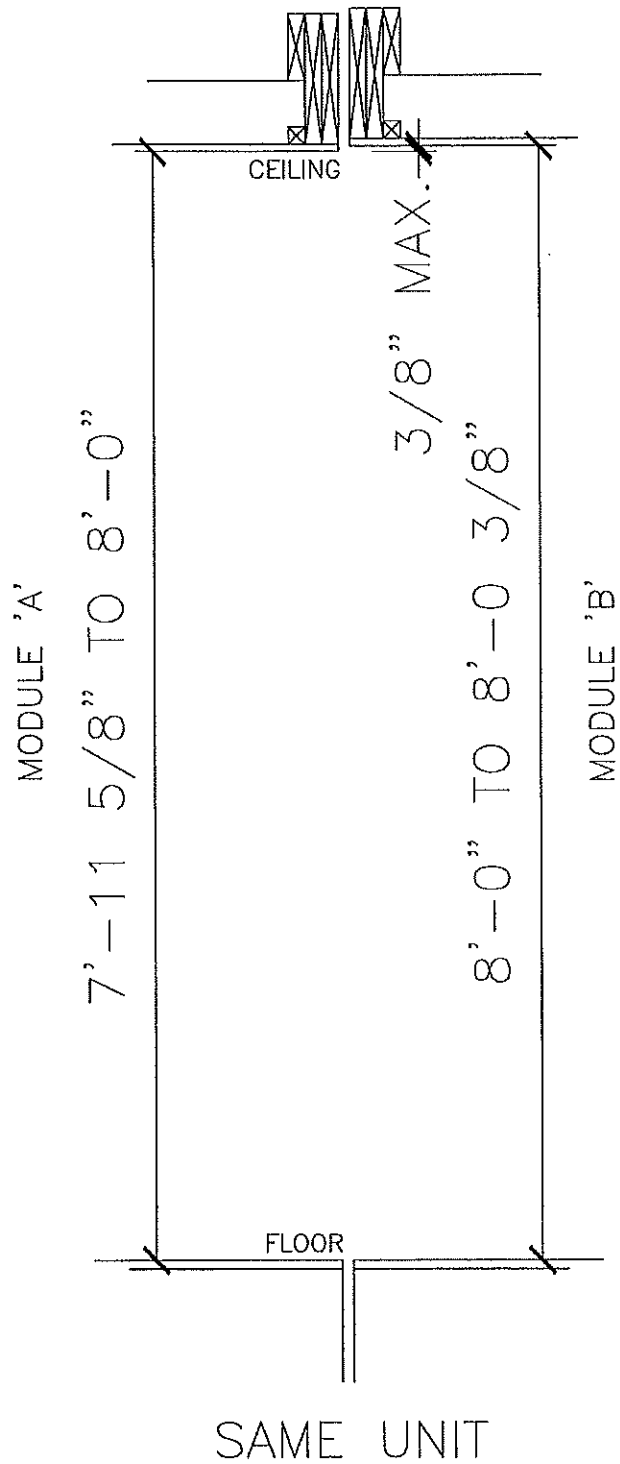

MODULAR TOLERANCES - FLOOR TO CEILING

Drawn By: CIC  
Scale: NONE  
Date: May 21, 2007  
Revisions: July 31, 2017

SK-C

# EXHIBIT "H"

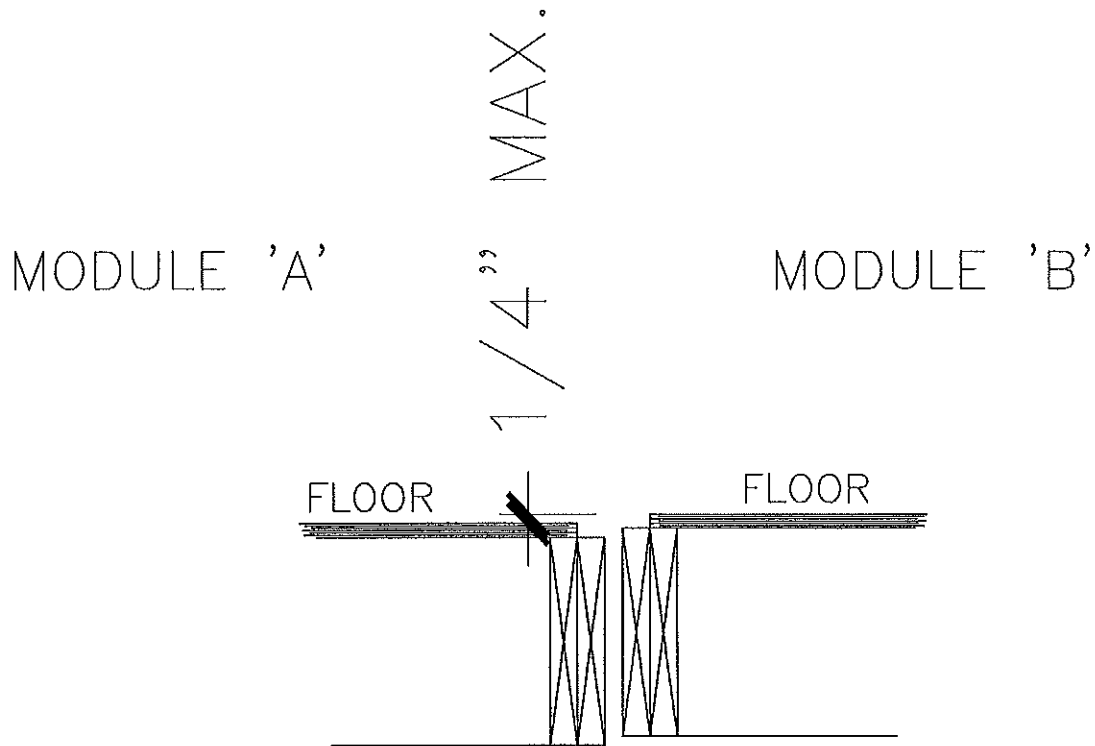

SAME UNIT



MODULAR TOLERANCES – FLOOR TO FLOOR

Drawn By: CIC  
Scale: NONE  
Date: May 21, 2007  
Revisions: July 31, 2017

SK-D

# EXHIBIT "H"

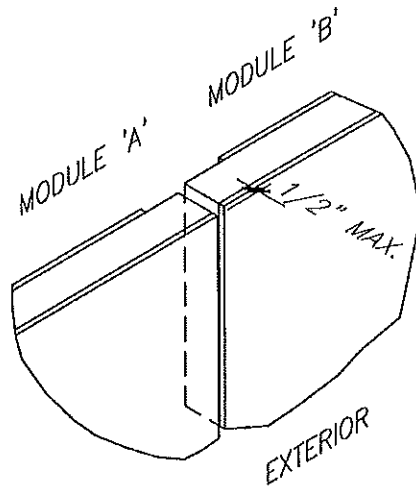
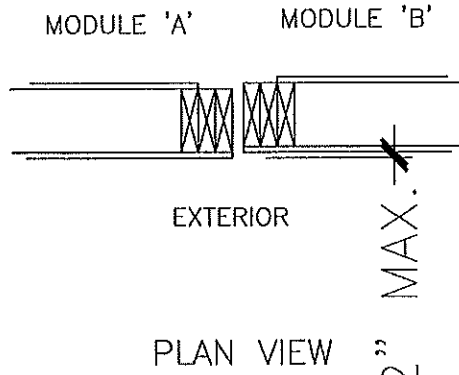

ISOMETERIC

SAME UNIT



MODULAR TOLERANCES - WALL TO WALL

Drawn By: CIC  
Scale: NONE  
Date: May 21, 2007  
Revisions: July 31, 2017

SK-E

# EXHIBIT "H"

MODULE 'A'

MODULE 'B'

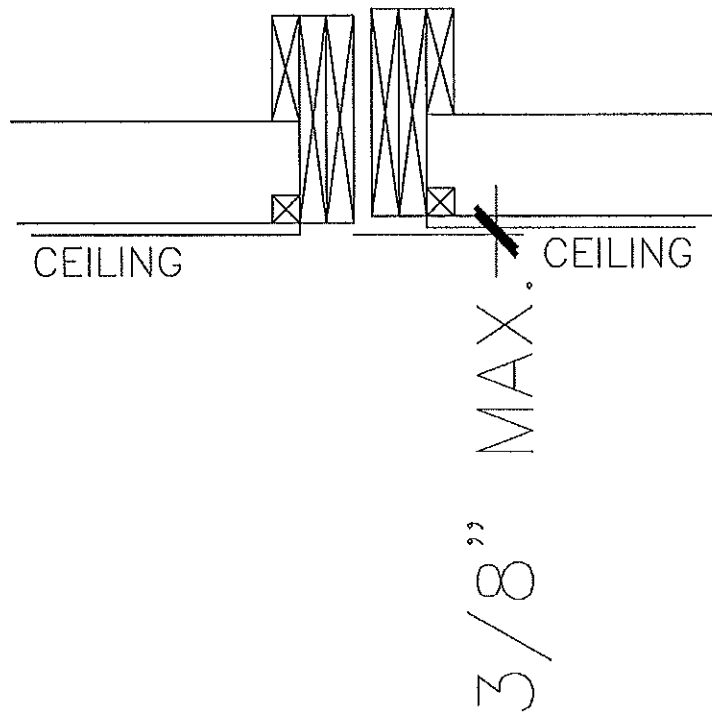

SAME UNIT



MODULAR TOLERANCES - CEILING TO CEILING

Drawn By: CIC

Scale: NONE

Date: May 21, 2007

Revisions: July 31, 2017

SK-F

# EXHIBIT "H"

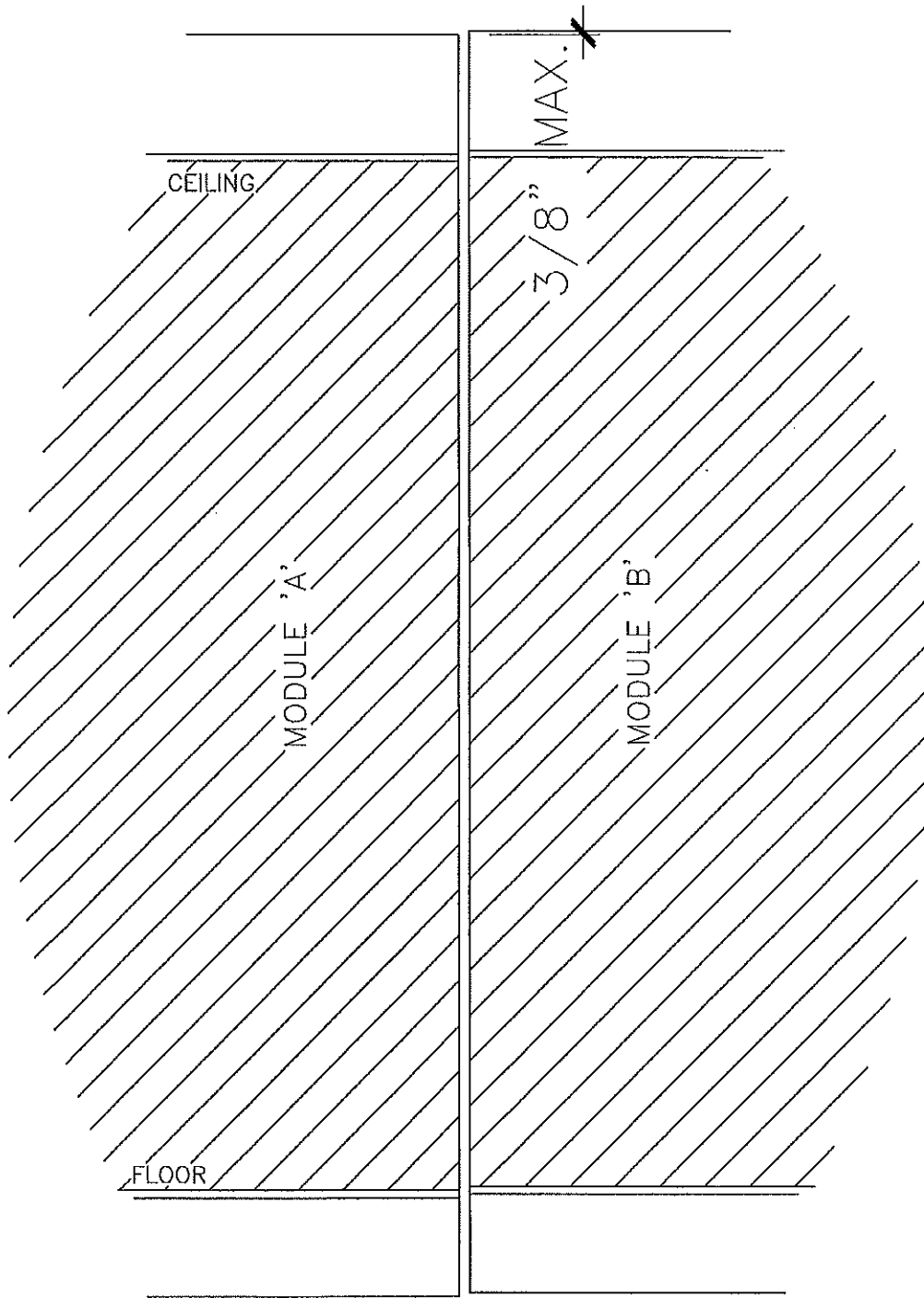

SAME UNIT

**Simplex**

Industries Inc.  
• BUILDERS OF QUALITY HOMES •  
KATONAH VALLEY INDUSTRIAL PARK  
3300 EX. HWY.  
SCHWARTZ, PA 15854

MODULAR TOLERANCES - FLOOR TO CEILING

Drawn By: CIG
Scale: NONE
Date: May 21, 2007
Revisions: July 31, 2017

SK-G

# EXHIBIT "H"

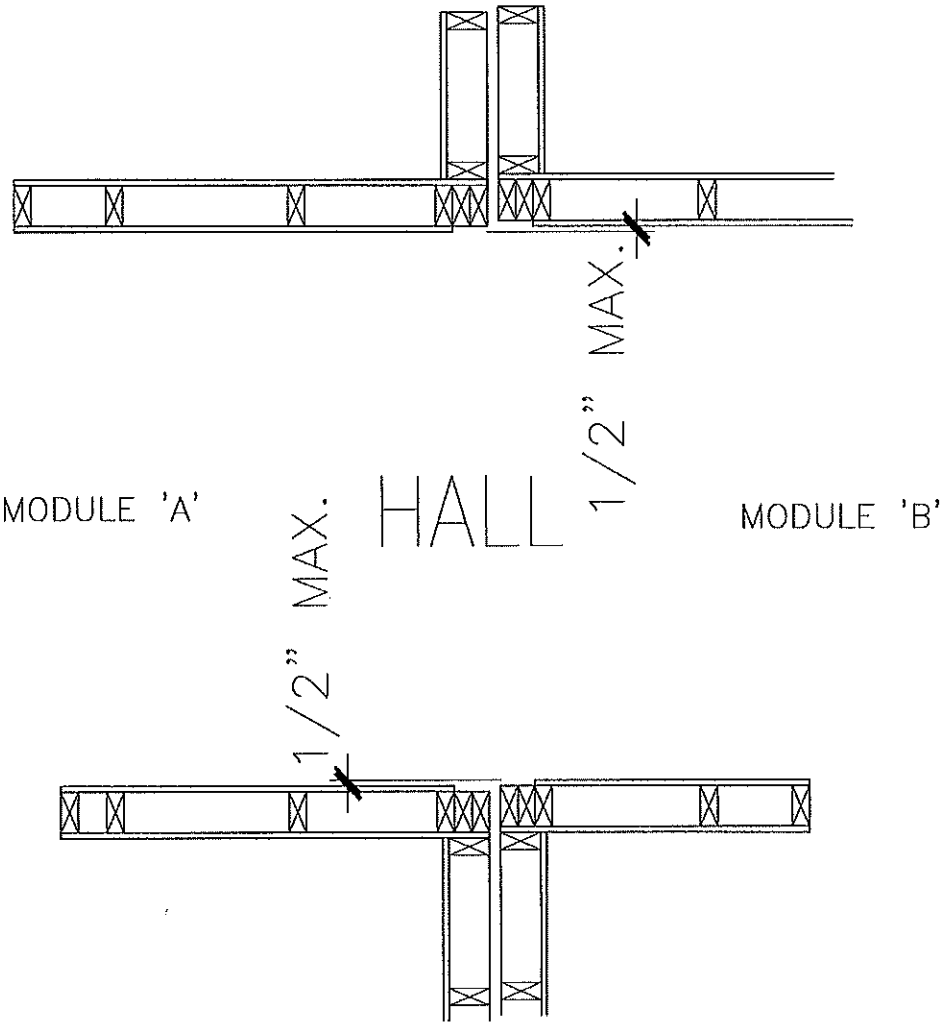

PLAN VIEW

SAME UNIT



MODULAR TOLERANCES - HALLWAYS

Drawn By: CIC
Scale: NONE
Date: May 21, 2007
Revisions: July 31, 2017

SK-H

# EXHIBIT "H"

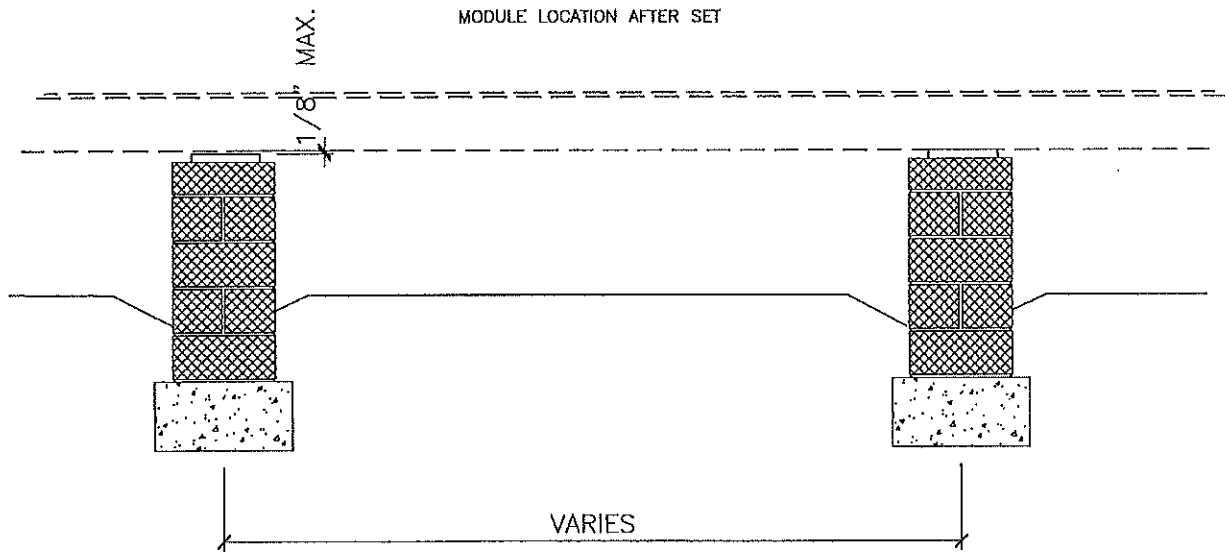
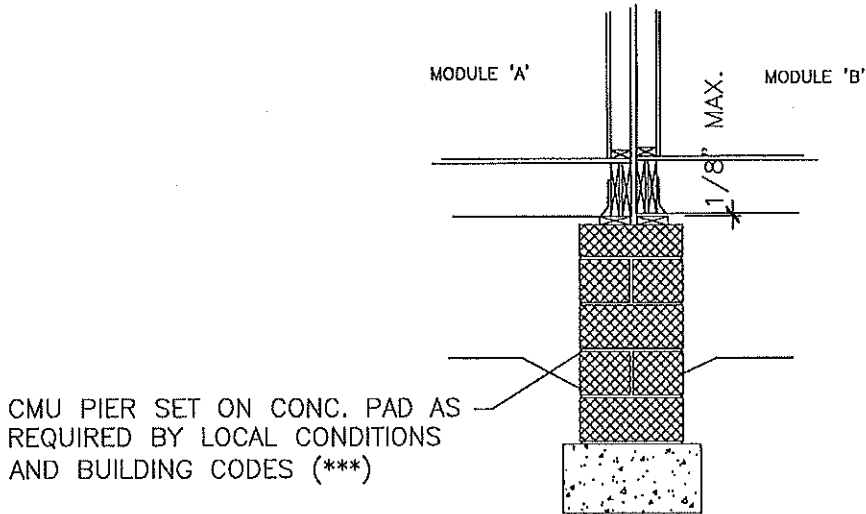

MODULAR TOLERANCES - PIER ELEVATIONS

Drawn By: CIC
Scale: NONE
Date: May 21, 2007
Revisions: July 31, 2017

SK-1



# EXHIBIT "H"

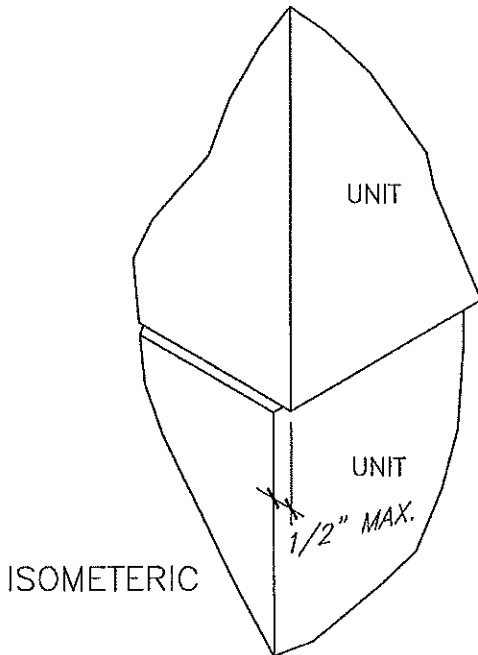
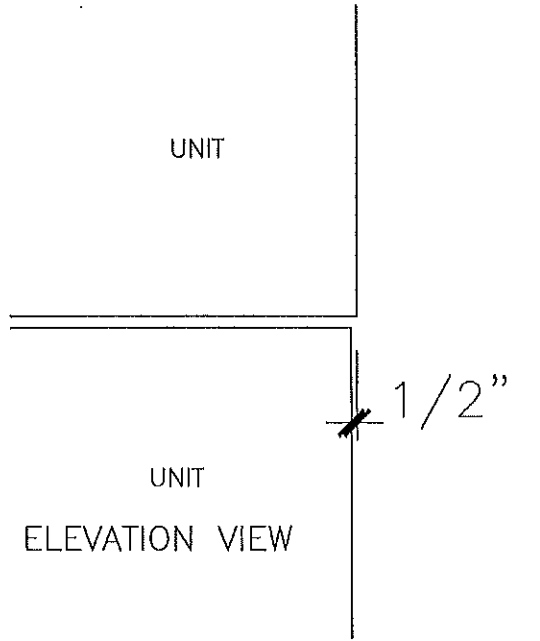

**Simplex**  
Industries Inc.  
• BUILDERS OF QUALITY HOMES •  
EVERETT VALLEY INDUSTRIAL PARK  
SUNBELT DRIVE  
SCALFORD, PA 18054

MODULAR TOLERANCES - BETWEEN UNITS  
VERTICAL

Drawn By: CIC
Scale: NONE
Date: May 21, 2007
Revisions: July 31, 2017

SK-J